

With Volvo Penta engines on board, uncompromising standards are built into your ship. Our comprehensive product program with engine outputs ranging from 100 to 1000 hp includes propulsion and auxiliary engines as well as complete marine generator sets. Advanced installation engineering ensures optimised durability and performance, while our extensive dealer network provides the service and parts which maximise engine lifetime. Ensuring high productivity and protecting the value of your investment.

Altogether, this makes Volvo Penta a leading worldwide supplier of power for marine professionals.

This document is not contractual. In a constant effort to improve the quality of its products, Volvo Penta reserves the right to modify any of the characteristics stated in this form without notice. For specific information on a certain engine model, please ask your dealer or visit our website www.volvopenta.com. All models are not available on all markets. The engines in the pictures may be fitted with extra optional equipment.

PRODUCT RANGE

Power for marine professionals



RATING DEFINITIONS

Rating definitions are to be used as a guideline to select the product that best suits the operational profile it is intended for. Ratings state the toughest allowed operation. Products can therefore also be used in higher rating applications: for example, a D13 Rating 3 engine can also be used for Rating 4 and Rating 5 applications. Ratings are not about emissions, type approvals or warranty conditions.

For complete warranty information, refer to Volvo Penta Warranty Information.

Rating 1 (Continuous Duty)

This power rating is intended for vessels with displacement hulls in heavy operation, unlimited number of running hours per year.

- Engine running hours per year are UNLIMITED.
- Load and speed could be constant, and full power can be used without interruption.

Typical boats could include but are not limited to: Coastal fishing boats, tugboats, trawlers, barges, ferries etc.

Rating 2 (Heavy Duty)

This power rating is intended for vessels with semi-planing or displacement hulls in cyclical operation.

- Engine running hours per year typically, but not limited to, 3-5000h.
- Full power could be utilized maximum 8 h per 12 h operation period.

Between full load operation periods, engine speed should be reduced at least 10% from the obtained full load engine speed, and the load should be cycled between 20%-85%.

Typical boats could include but are not limited to: Patrol and pilot boats, Fishing boats, Passenger, crew and work boats etc.

Rating 3 (Medium Duty)

This power rating is intended for commercial vessels with high demands on speed and acceleration, planing or semi-planing hulls in cyclical operation.

- Engine running hours per year typically, but not limited to 2000-3000h

- Full power could be utilized maximum 2 h per 12 h operation period. Between full load operation periods, engine speed should be reduced at least 10% from the obtained full load engine speed, and the load should be cycled between 20%-85%.

Typical boats could include but are not limited to: Fast patrol, rescue, police, light fishing, taxi boats, offshore supply, coastguard boats and high-speed passenger ferries etc.

Rating 4 (Light Duty)

This power rating is intended for light planing vessels in commercial operation.

- Running hours per year typically, but not limited to 800-1500h.
- Full power could be utilized maximum 1 h per 12 h operation period. Between full load operation periods, engine speed should be reduced at least 10% from the obtained full load engine speed, and the load should be cycled between 20%-85%.

Typical boats could include but are not limited to: High-speed patrol, navy, rescue, police, ambulance, offshore supply, coastguard boats, high-speed passenger ferries and special high speed fishing boats, pleasure craft etc.

Rating 5 (High Performance & Pleasure Duty)

This power rating is intended for high speed planing craft and pleasure craft, governmental or commercial applications with special limited warranty, see warranty handbook.

- Running hours per year typically, but not limited to 50-500h.
- Full power could be utilized maximum 1 h per 12 h operation period. Between full load operation periods, engine speed should be reduced at least 10% from the obtained full load engine speed, and the load should be cycled between 20%-85%.

Typical boats could include but are not limited to: Pleasure craft incl sailboats, High-speed patrol, navy, rescue, police, ambulance boats, high speed fishing boats etc.

EMISSION CONTROL AREAS (ECA)

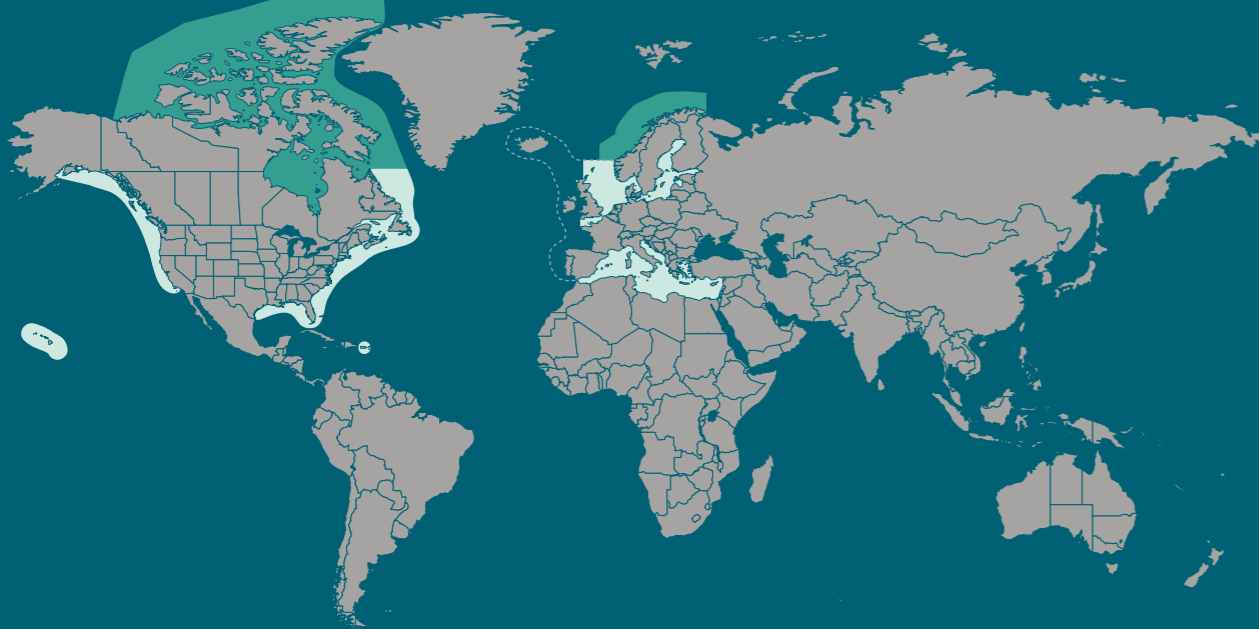

Existing ECAs

- North American area¹⁾**
IMO III – (SECA²⁾ + NECA³⁾ – 1 Jan 2016
- US Caribbean Sea area**
IMO III – (SECA²⁾ + NECA³⁾ – 1 Jan 2016
- North Sea & Baltic Sea**
IMO III – (SECA²⁾ + NECA³⁾ – 1 Jan 2021
- Mediterranean Sea**
IMO II – (SECA²⁾) – 1 May 2025
- Global unless otherwise stated**
IMO II

Domestic marine commercial emission legislation

- Europe Inland Water Ways – Stage V
- China Marine Stage II
- US EPA Tier 3 (P<600 KW)

Future ECAs

- Canadian Arctic**
IMO III – (SECA²⁾ + NECA³⁾ – 1 Jan 2025
- Norwegian waters**
IMO III – (SECA²⁾ + NECA³⁾ – ships contracted on or after 1 March 2026; or in the absence of a contract, keel-laid on or after 1 September 2026; or delivered on or after 1 March 2030.
- North East Atlantic**
– – – – Boundry to be confirmed. Still just a draft with no approval and no dates.

1) If a US flagged commercial ship, with engine power less than 600 kW/engine, only operates in US domestic waters, i.e. no international travels, IMO II and US EPA Tier 3 will be sufficient.

2) **SECA*** – Reduces SOx (Sulphur Oxide) and PM emissions (Particulate Matter). SOx triggers fine PM emissions which leads to health impacts and acid rain. SECA encourages ships to use cleaner fuels.

3) **NECA*** – Reduces NOx (Nitrogen Oxide) emissions. NOx causes health impacts and eutrophication and acidification of water, which disrupts aquatic and terrestrial ecosystems.

* References; Clean Arctic Alliance and Torstein Ingebrigtsen Bø. (2016). Scenario- and Optimization-Based Control of Marine Electric Power Systems (thesis). Trondheim.

Note! Map is only for illustration.

AT THE LEADING EDGE IN MARINE DIESELS

Volvo Penta is a solid partner in providing marine power systems. The combined technological resources provided by the Volvo Group, coupled with our tradition of innovative marine engineering, enable us to design and deliver diesel performance for a broad range of marine applications – and to provide service and support all over the world.

Prepared for future emission standards

Our focus in product development and renewal is on achieving even greater reliability, performance and fuel efficiency. Continuous progress in environmental performance ensures that our power range will meet the emission standards introduced in the future.

Engines and complete drive systems for marine professionals

- Extensive product range developed for a broad range of marine applications
- 4–16 litre diesel engines with drive, control and monitoring systems to match
- Type-approved engines, delivered, tested and ready for installation
- Customised parts kits and efficient parts supply through the extensive network of qualified and well-equipped service dealers

Rating definitions

Rating definitions are to be used as a guideline to select the product that best suits the operational profile it is intended for. Ratings state the toughest allowed operation. Products can therefore also be used in higher rating applications: for example, a D13 Rating 3 engine can also be used for Rating 4 and Rating 5 applications. Ratings are not about emissions, type approvals or warranty conditions.

For complete warranty information, refer to Volvo Penta Warranty Information.

TABLE OF CONTENTS

Engine range overviews

From power to superpower	5
Testing for the real world	6
Alternative fuels – Dual Fuel engines	7
Alternative fuels	7
HVO	8
Electromobility in sightseeing	9
Electromobility at sea	10
Volvo Penta IMO III	12
Diesel Inboard & Auxiliary engines	14
Diesel Aquamatic	22
Volvo Penta IPS	26
Marine gensets	30
Volvo Penta Accessories	36
Uptime & Cost of ownership	38

THE FUTURE BELONGS TO THOSE WHO ENGINEER IT

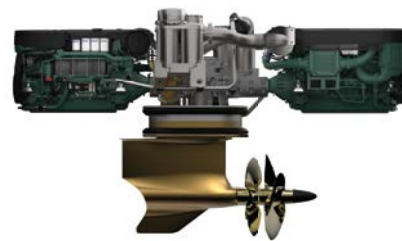

THE VOLVO PENTA IPS PROFESSIONAL PLATFORM

From power to Superpower

Introducing the new Volvo Penta Inboard Performance System (IPS) professional platform. Designed, verified and serviced by one integrator, Volvo Penta, the platform is the next evolution in our fully integrated helm-to-propeller experience. A successor to our previous pioneering solutions, the new Volvo Penta IPS professional platform is the evolution of a revolution, created by some of the most forward-thinking experts in the marine industry. For close to 20 years, Volvo Penta IPS has provided a unique and unrivalled experience with an instant response and fast acceleration for a wide range of recreational and professional vessels with approximately 40,000 units delivered.

Designed around you

Delivering a seamless and intuitive experience, the Volvo Penta IPS professional platform is designed to take care of you – both on and off board. Its driveline's innovative new design with dual power inputs unlocks a range of possibilities for managing the power to the water in the most efficient way possible, by enabling different power sources to be connected to one efficient drive. The design is supported by an intelligent system equipped with the latest trademark technology from Volvo Penta - a smart EcoMode feature that will automatically manage and optimize the use of power based on real-time needs during operation.



Testing for the real world

The offshore field test, initiated in a rugged environment, demonstrates the resilience and effectiveness of the new Volvo Penta IPS professional platform. This testing phase, under challenging weather and treacherous seas, is critical to assess the platform's performance in real-world conditions. Offshore wind farms globally rely on crew transfer vessels to ferry technicians from the mainland to the wind turbines. These operations require the vessel to closely approach and push up against the wind turbines, demanding superior maneuverability to ensure quick, efficient, and safe transfers. The Volvo Penta IPS professional platform, with its robust build and unparalleled durability, proves to be an excellent fit not just for these demanding commercial operations but also adapts seamlessly for diverse applications such as people transportation, sightseeing vessels, short sea operations, pilots, and patrol duties. Its versatile capabilities make it ideal for ensuring safety and efficiency across various maritime tasks, even in the most challenging conditions.

Sustainability is also high in focus as the vessels are operating at sea in low speed, where energy efficiency is a key driver for the future in line with the growing needs of the offshore energy sector. The platform is an ideal match to meet these tough demands – and is entering into its first field test in an offshore wind farm during 2024.

Alternative fuels Dual Fuel engines

Volvo Penta and CMB.TECH have collaborated to develop innovative dual-fuel hydrogen-diesel engines, significantly advancing sustainable marine technology. Their joint efforts have successfully powered Hydrobingo, a pioneering hydrogen-diesel dual-fueled commercial ferry operating off Japan's coast. This vessel, utilizing Volvo Penta's D13 engines, demonstrates the practical application and environmental benefits of dual-fuel technology, achieving notable reductions in CO₂ and NO_x emissions. This partnership between Volvo Penta and CMB.TECH not only showcases the potential of hydrogen as a sustainable power source but also marks a crucial step towards achieving net-zero emissions in the marine industry.

Alternative fuels The future is flexible

Volvo Penta is actively exploring the horizons of innovation, where the pursuit of sustainability meets cutting-edge technology. Our journey into experimenting with several alternative fuels like for example, hydrogen and methanol is driven by our commitment to creating a cleaner, more sustainable future. This exploration redefines the conventional, stretching the limits of innovation in marine and industrial power systems, while upholding Volvo Group's commitment to the Paris Agreement and the goal of achieving net zero emissions by 2040.



HVO Without any adjustments needed

Since 2016, Volvo Penta's diesel engines are fully compatible with HVO. This renewable fuel aligns with the CEN standard EN 15940 and is a robust solution for marine use. As a testament to its effectiveness, one of Volvo Penta's clients, Clinton Marine Survey has adeptly integrated HVO into their operations, efficient ocean mapping. They lead their industry with a unique approach, integrating the renewable diesel alternative, to significantly reduce their carbon footprint. HVO typically comes at a higher cost compared to conventional diesel. To offset this, Clinton Marine Survey has adapted their client charging model, outlined in the scope of work to reflect the added value of their environmentally responsible operations. They transparently communicate the benefits of reduced CO2 emissions to their clients, justifying the premium. This approach not only aligns with their sustainability goals but also resonates with a growing segment of environmentally conscious clients.

HVO CAN BE SUMMARIZED IN:

Performance: HVO maintains operational efficiency and reliability.

Flexibility: HVO can be used either in its pure form or blended with conventional diesel.

Maintenance: As a drop in fuel, no change in maintenance or service schedules when switching to HVO. HVO offers an immediate, sustainable solution for reducing CO2 emissions.

Ease of Transition: Switching to HVO involves simply refueling with HVO100 instead of conventional diesel.

Electromobility in sightseeing Access the inaccessible

Navigating the serene yet demanding Arctic waters of Svalbard, the Kvitbjørn stands as a testament to the prowess of electromobility in maritime engineering. This vessel, powered by a D6-400 PHEV DPI Aquamatic hybrid-electric solution, represents a collaborative venture between Volvo Penta, Marell Boats, and Hurtigruten Svalbard. The partnership has embarked on a three-year pilot project, aiming to rigorously test cutting-edge electromobility solutions in one of the planet's most challenging maritime environments, known for stringent emission regulations.

Engineered for precision and adaptability, the vessel features a fully integrated, helm-to-propeller hybrid system. Central to this setup are Volvo Penta's advanced technologies, including an intuitive joystick and an electric-mode-enabled Dynamic Positioning System. These features ensure unparalleled control, allowing the vessel to manoeuvre gracefully through the icy waters, offering passengers a seamless and serene experience.

Innovatively, this project transcends traditional boundaries, pioneering a new paradigm - electromobility as a service. This model not only enhances operational efficiency but also aligns with the evolving demands of the passenger vessel and sightseeing industry, offering a sustainable, adaptable, and experience-focused approach to maritime travel.



Electromobility at Sea

The Power of Flexibility with Volvo Penta's Serial Hybrid.

Embracing the future of marine propulsion, the Volvo Penta serial hybrid solution stands at the forefront of electromobility. This innovative system, powering MHO-Co's CTVs - MHO Boreas and Balder. The ships are themselves a masterpiece of engineering, blending the best of electric and diesel technology, breaking new ground for each iteration in which Boreas and Balder are the latest.

The heart of their hybrid systems lies in their flexibility, both in terms of design and system architecture. In dynamic environments like the North Sea, the serial hybrid effortlessly shifts between electric and diesel modes. This adaptability is crucial, allowing for full electric operation in situations demanding lower power and seamlessly switching to full diesel in higher-demand scenarios. A key advancement towards achieving true decarbonized operation lies in the strategic integration of batteries alongside diesel generators (gensets). This combination not only makes decarbonized operations practically feasible but also addresses the limitations associated with full battery packs, which can be too heavy and expensive for widespread use. For the foreseeable future, innovative approaches like the MHO 2 model will continue to emerge, where gensets are gradually replaced by various types of more environmental friendly power sources or more efficient battery packs. This evolution underscores the flexibility offered by a fully electric drivetrain.

A significant advantage of this system is the consolidation of power sources. Unlike traditional setups that rely on multiple engines running at idle speed—a process that is inherently inefficient—having one power source for all four drivelines substantially reduces running hours and maintenance costs.

Another key feature enhancing this system's efficiency is the Dynamic Positioning System-mode, where the hybrid solution truly showcases its prowess. Operating below 20 liters per hour, it sets a new benchmark for efficiency in Crew Transfer Vessel (CTV) operations. This achievement not only reflects Volvo Penta's commitment to sustainable solutions but also demonstrates the tangible benefits of serial hybrid technology in challenging marine conditions. The journey of MHO Boreas and MHO Balder is more than a testament to Volvo Penta's innovation; it's a bold step into a future where flexibility and sustainability navigate together, marking a significant stride in the maritime industry's move towards more eco-friendly and efficient operations.

VOLVO PENTA IMO III

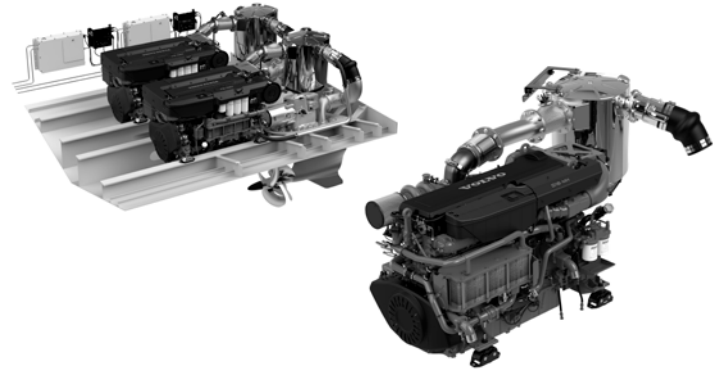

The Volvo Penta IMO Tier III solution is uniquely designed, developed and tested for tough marine conditions. Based on SCR exhaust aftertreatment technology, our solution is designed for flexibility, ease of installation and space-efficient configuration.

Ease of installation, ease of operation

As a large part of the installations are made during repowering, we have prioritized utilization of machine room space and created a design of the SCR unit that allows for space-efficient configuration possibilities.

Our type approved solution is developed, certified, monitored and maintained by one single supplier. One complete system, including all functions with one single point of contact. One tool for service technicians. One interface for operators.

The Volvo Penta IMO Tier III solution is available for our D8, D13 and D16 diesel in-board, marine genset and auxiliary applications – as well as for D13 Volvo Penta IPS installations.

DIMENSIONS AND WEIGHTS

Engine	L (mm)	W1 (mm)	W2 (mm)	H (mm)	kg	lb
SCR unit D8 excl. bracket	770	491	600	666	130*	286*
SCR unit D13 excl. bracket	720	681	826	806	136*	299*
SCR unit D16 excl. bracket	720	681	826	806	136*	299*

The SCR unit can be installed either vertically or horizontally, allowing for multiple configuration possibilities.

VOLVO PENTA IMO III

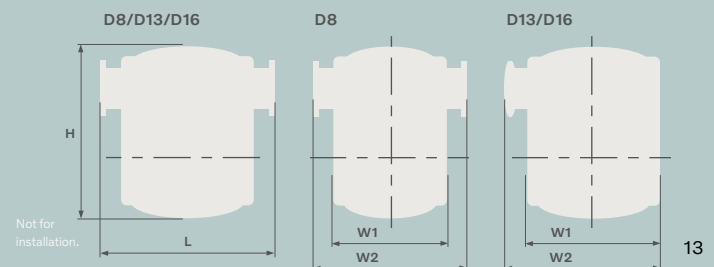

DIESEL INBOARD & AUXILIARY ENGINES



Power for displacement craft

The heavy-duty range has been developed for extreme reliability. These marine combustion engines are designed to keep running, year in and year out.

The basic design features robust engine blocks manufactured from high-strength castings, large bearing surfaces and powerful crankshafts with all components engineered to withstand the toughest conditions.

Low fuel consumption is high priority, as are low maintenance costs, exhaust and noise emissions and simple service – properties that are vitally important for the crew as well as the environment.

Power for planing craft

Volvo Penta diesel technology delivers performance without sacrificing reliability. Whether electronically controlled or mechanically governed, all marine diesels in the range provide the necessary performance for applications requiring fast acceleration and high top speed.

The Volvo Penta range today offers combinations of high power, low weight, low fuel consumption and emissions that were inconceivable only a few years ago.

Auxiliary engines

Diesel inboard rating 1, rating 2 and marine genset engines can be used also for various auxiliary applications.

D4 MARINE ENGINE



4-cylinder, 4-stroke, direct-injected turbo-charged, and aftercooled marine diesel engine.

Bore x Stroke (mm): 103 x 110

Displacement (l): 3.67

PROPULSION & AUX ENGINE

Engine	kW	hp	Rated rpm	Rating	Emission certificate**	Emissions curve	Cooling system
D4-175 I	129	175	2800	4	1, 2, 4	E3	HE
D4-230 I	169	230	3400	4	1, 2, 4	E3	HE
D4-270 I	199	270	3500	4	1, 2, 4	E3	HE
D4-300 I	221	300	3500	5	1, 2, 4	E3	HE
D4-320 I	235	320	3600	5	1, 2, 4	E3	HE

HE = Heat Exchanger

DIMENSIONS AND WEIGHTS*

Engine	L (mm)	W (mm)	H (mm)	kg	lb
D4-175	801	848	794	560	1235
D4-230	801	848	794	565	1246
D4-270	801	848	794	580	1279
D4-300	801	848	794	580	1279
D4-320	801	848	794	610	1345

* Dimensions and weights based on bobtail engines.

** Emission Certificate:

- 1 – IMO tier II
- 2 – EPA Tier 3
- 4 – China II

D6 MARINE ENGINE



6-cylinder, 4-stroke, direct-injected turbo-charged, and aftercooled marine diesel engine.

Bore x Stroke (mm): 103 x 110

Displacement (l): 5.5

PROPULSION & AUX ENGINE

Engine	kW	hp	Rated rpm	Rating	Emission certificate**	Emissions curve	Cooling system
D6-300 I	221	300	3300	4	1, 2, 4	E3	HE
D6-340 I	250	340	3400	4	1, 2, 4	E3	HE
D6-380 I	280	380	3500	4	1, 2, 4	E3	HE
D6-440 I	324	440	3700	5	1, 2, 4	E3	HE
D6-480 I	353	480	3700	5	1, 2, 4	E3	HE
D6-440 I WJ	324	440	3700	5	1, 2, 4	E3	HE
D6-480 I WJ	353	480	3700	5	1, 2, 4	E3	HE

HE = Heat Exchanger

DIMENSIONS AND WEIGHTS*

Engine	L (mm)	W (mm)	H (mm)	kg	lb
D6-300	1035	851	780	695	1532
D6-340	1035	851	780	720	1587
D6-380	1035	851	780	720	1587
D6-440	1035	851	795	755	1664
D6-480	1035	851	795	755	1664
D6-440 WJ	1035	851	795	625	1378
D6-480 WJ	1035	851	795	625	1378

* Dimensions and weights based on bobtail engines.

** Emission Certificate:

- 1 – IMO tier II
- 2 – EPA Tier 3
- 4 – China II

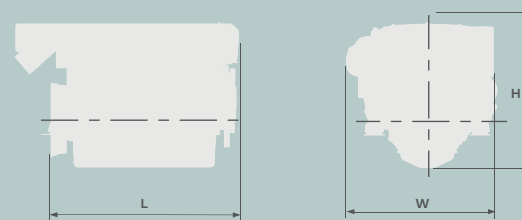
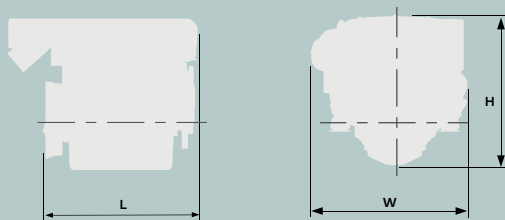

D8 MARINE ENGINE



6-cylinder, 4 stroke, direct-injected, common rail, turbo-charged, and aftercooled marine diesel engine.

Bore x Stroke (mm): 110 x 135

Displacement (l): 7.7

All MH engines available as Aux

PROPULSION & AUX ENGINE

Engine	kW	hp	Rated rpm	Rating	Emission certificate**	Emissions curve	Cooling system
D8-450	331	450	2700	3	1, 2, 4	E3	HE
D8-510	374	509	2850	4	1, 2, 4	E3	HE
D8-550	405	550	2900	4	1, 2, 4	E3	HE
D8-MH	154	209	2200	1	1	E3/E2/C1	HE, KC
D8-MH	169	230	2200	1	1	E3/E2/C1	HE, KC
D8-MH	195	265	2200	1	1	E3/E2/C1	HE, KC
D8-MH	221	301	2200	1	1	E3/E2/C1	HE, KC
D8-MH	261	355	2200	1	1, 4	E3/E2/C1	HE, KC
D8-MH	296	403	2200	2	1, 2, 4, 5	E3/E2/C1	HE, KC
D8-MH	272	370	2200	1	1, 2, 4, 5	E3/E2/C1	HE, KC
D8-MH	313	425	2200	2	1, 2, 4, 5	E3/E2/C1	HE, KC
D8-MH IMOIII IWW***	154	209	2200	1	2, 6, 7	E3/E2/C1	HE, KC
D8-MH IMOIII IWW***	169	230	2200	1	2, 6, 7	E3/E2/C1	HE, KC
D8-MH IMOIII IWW***	195	265	2200	1	2, 6, 7	E3/E2/C1	HE, KC
D8-MH IMOIII IWW***	221	301	2200	1	2, 6, 7	E3/E2/C1	HE, KC
D8-MH IMOIII IWW***	261	355	2200	1	2, 6, 7	E3/E2/C1	HE, KC
D8-MH IMOIII IWW***	298	405	2200	2	2, 6, 7	E3/E2/C1	HE, KC
D8-MH IMOIII	313	426	2200	2	2, 6, 7	E3/E2/C1	HE, KC

HE = Heat Exchanger, KC= Keel

DIMENSIONS AND WEIGHTS*

Engine	L (mm)	W (mm)	H (mm)	kg	lb
D8	1263	987	1006	840	1840
D8 MH	1263	1052	1014	850	1874

* Dimensions and weights based on bobtail engines.

*** Emissions cert für EU Stage V - IWW (2016/1628)

** Emission Certificate:

- 1 – IMO tier II
- 2 – EPA Tier 3
- 3 – China I
- 4 – China II
- 5 – IMO tier II & EPA only available on request.
- 6 – IMO tier III
- 7 – EU Stage V – Inland Water Way



Not for installation.

D11 MARINE ENGINE



6-cylinder, 4 stroke, direct-injected, turbo-charged, and aftercooled marine diesel engine.

Bore x Stroke (mm): 123 x 152

Displacement (l): 10.84

PROPULSION & AUX ENGINE

Engine	kW	hp	Rated rpm	Rating	Emission certificate**	Emissions curve	Cooling system
D11-510	374	510	2250	3	1, 2	E3	HE
D11-625	459	625	2400	4	1, 2	E3	HE

HE = Heat Exchanger

DIMENSIONS AND WEIGHTS*

Engine	L (mm)	W (mm)	H (mm)	kg	lb
D11	1309	977	1096	1145	2524

* Dimensions and weights based on bobtail engines.

** Emission Certificate:

- 1 – IMO tier II
- 2 – EPA Tier 3

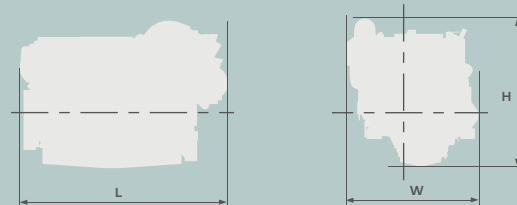

Not for installation.

D13 MARINE ENGINE



6-cylinder, 4-stroke, direct-injected, twin-entry, and turbo-charged marine diesel engine.

Bore x Stroke (mm): 131 x 158

Displacement (l): 12.78

PROPULSION & AUX ENGINE

Engine	kW	hp	Rated rpm	Rating	Emission certificate**	Emissions curve	Cooling system
D13-MH	294	400	1800	1	1, 2, 4, 5	E3/E2/C1	HE, KC, RC
D13-MH	331	450	1800	1	1, 2, 4, 5	E3/E2/C1	HE, KC, RC
D13-MH	368	500	1800	1	1, 2, 4, 5	E3/E2/C1	HE, KC, RC
D13-MH	404	550	1900	2	1, 2, 4, 5	E3/E2	HE, KC, RC
D13-MH	441	600	1900	2	1, 2, 4, 5	E2/E3/C1	HE, KC, RC
D13-MH	294	400	1800	1	2, 6	E3/E2/C1	HE, KC, RC
D13-MH	331	450	1800	1	2, 6	E3/E2/C1	HE, KC, RC
D13-MH	368	500	1800	1	2, 6	E3/E2/C1	HE, KC, RC
D13-MH	441	600	1900	2	2, 6	E3/E2/C1	HE, KC, RC
D13-MH (FE)	214	291	1800	1	1	E3	HE, KC, RC
D13-MH (FE)	294	400	1800	1	1	E3/E2/C1	HE, KC, RC
D13-MH (FE)	331	450	1800	1	1	E3/E2/C1	HE, KC, RC
D13-MH (FE)	368	500	1800	1	1	E3/E2/C1	HE, KC, RC
D13-MH (FE)	404	550	1900	2	1	E3/E2/C1	HE, KC, RC
D13-MH (FE)	441	600	1900	2	1	E3/E2/C1	HE, KC, RC
D13-700	515	700	2250	2	1, 2, 4, 5	E3	HE
D13-800	588	800	2300	3	1, 2, 4, 5	E3	HE
D13-900	662	900	2300	4	1, 4, 5	E3	HE
D13-1000	735	1000	2400	5	1, 4, 5	E3	HE
D13-700 IMOIII	515	700	2250	2	2, 6	E3/C1	HE
D13-800 IMOIII	588	800	2300	3	2, 6	E3/C1	HE
D13-900 IMOIII	662	900	2300	4	6	E3/C1	HE
D13-1000 IMOIII	735	1000	2400	5	6	E3/C1	HE
D13-MH StageV	294	400	1800	1	7	E3/E2/C1	HE, KC, RC

HE = Heat Exchanger, KC = Keel, RC = Radiator

DIMENSIONS AND WEIGHTS*

Engine	L (mm)	W (mm)	H (mm)	kg	lb
D13 MH	1728	1072	1501	1520	3351
D13-700 ***	1420	1062	1053	1560	3439
D13-800 ***	1420	1089	1220	1560	3439
D13-900 ***	1420	1089	1220	1560	3439
D13-1000	1420	1089	1220	1635	3604

* Dimensions and weights based on bobtail engines.

** Emission Certificate: 1 – IMO tier II 2 – EPA Tier 3 4 – China II

5 – IMO tier II & EPA only available on request 6 – IMO tier III 7 – EU Stage V – Inland Water Way

*** Engine has DST (Dual Stage Turbo).

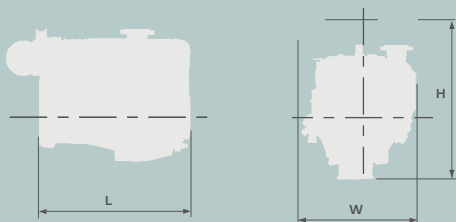

Not for installation.

D16 MARINE ENGINE



6-cylinder, 4-stroke, direct-injected, turbo-charged, and aftercooled marine diesel engine.

Bore x Stroke (mm): 144 x 165

Displacement (l): 16.12

PROPULSION & AUX ENGINE

Engine	kW	hp	Rated rpm	Rating	Emission certificate**	Emissions curve	Cooling system
D16-MH	441	600	1800	1	1, 2, 4, 6	E3/E2/C1	HE, KC, RC
D16-MH	441	600	1800	1	1, 2, 4, 6	E3/E2/C1	HE, KC, RC
D16-MH	441	600	1800	1	1, 2, 4, 6	E3/E2/C1	HE, KC, RC
D16-MH	478	650	1800	1	1, 2, 4, 6	E3/E2/C1	HE, KC, RC
D16-MH	478	650	1800	1	1, 2, 4, 6	E3/E2/C1	HE, KC, RC
D16-MH	478	650	1800	1	1, 2, 4, 6	E3/E2/C1	HE, KC, RC
D16-MH	551	750	1900	1	1, 2, 4, 6	E3/E2/C1	HE, KC, RC
D16-MH	551	750	1900	1	1, 2, 4, 6	E3/E2/C1	HE, KC, RC
D16-MH	551	750	1900	1	1, 2, 4, 6	E3/E2/C1	HE, KC, RC
D16-MH	588	800	1900	2	1, 2, 4, 6	E3/E2/C1	HE, KC, RC
D16-MH	588	800	1900	2	1, 2, 4, 6	E3/E2/C1	HE, KC, RC
D16-MH	588	800	1900	2	1, 2, 4, 6	E3/E2/C1	HE, KC, RC
D16-MH	625	850	1900	2	1, 4, 6	E3/E2/C1	HE, KC, RC
D16-MH	625	850	1900	2	1, 4, 6	E3/E2/C1	HE, KC, RC

HE = Heat Exchanger, KC = Keel, RC = Radiator

DIMENSIONS AND WEIGHTS*

Engine	L (mm)	W (mm)	H (mm)	kg	lb
D16 MH	1531	1327	1276	1810	3990

* Dimensions and weights based on bobtail engines.

** Emission Certificate:

1 – IMO tier II

2 – EPA Tier 3

4 – China II

5 – IMO tier II & EPA only available on request.

6 – IMO tier III



Not for installation.

DIESEL AQUAMATIC DRIVES

VOLVO PENTA
D6-400



The Duoprop drive

Duoprop is Volvo Penta's revolutionary sterndrive that introduced a new era in marine propulsion. By placing two counter-rotating propellers on a single axis system, the Duoprop technology, in combination with the D4 or D6 engines, provides superior handling by eliminating the torque steer common to all single-prop systems. The counter-rotating aft prop reverses the swirl loss generated by the front propeller and converts it to additional thrust. All of which helps deliver up to 15% more power, 20% better acceleration, and 15% better fuel efficiency over single-propeller sterndrives. Duoprop also minimises cavitation, improves handling at slow speeds, and reduces steering force, hull roll and vibration.

DPI Duoprop

Exclusively developed to handle the tremendous torque and power of the D4 and D6 diesel engines. Features silent shift and slipping functionality at low speeds for precise and smooth manoeuvring. Stainless steel propellers designed for optimal interaction between front and rear propellers, for outstanding efficiency and smooth and comfortable operation.

DPH Duoprop

Available for single installations with hydraulic steering. Equipped with nickel-bronze-aluminium propellers.

D4 AQUAMATIC



4-cylinder, 4-stroke, direct-injected, and aftercooled marine diesel engine.

Bore x Stroke (mm): 103 x 110

Displacement (l): 3.7

PROPULSION

Engine	Drive	Crankshaft power kW/hp	Prop. shaft power kW/hp	Rated rpm	Number of Cyl.	Displ. liters / in ³	Rating	Cooling system
D4-150A	DPI	110 / 150	106 / 144	3400	4	3.7 / 224	4	HE
D4-150A	DPH	110 / 150	106 / 144	3400	4	3.7 / 224	4	HE
D4-230A	DPI	169 / 230	162 / 221	3400	4	3.7 / 224	4	HE
D4-230A	DPH	169 / 230	162 / 221	3400	4	3.7 / 224	4	HE
D4-270A	DPI	199 / 270	191 / 259	3500	4	3.7 / 224	4	HE
D4-270A	DPH	199 / 270	191 / 259	3500	4	3.7 / 224	4	HE
D4-300A	DPI	221 / 300	212 / 288	3500	4	3.7 / 224	5	HE
D4-300A	DPH	221 / 300	212 / 288	3500	4	3.7 / 224	5	HE
D4-320A	DPI	235 / 320	226 / 307	3600	4	3.7 / 224	5	HE

HE = Heat Exchanger

DIMENSIONS AND WEIGHTS*

Engine	L (mm)	W (mm)	H (mm)	kg	lb
D4-150/DPI	1129	848	780	655	1444
D4-150/DPH	1129	848	780	645	1422
D4-230/DPI	1129	848	780	655	1444
D4-230/DPH	1129	848	780	645	1422
D4-270/DPI	1129	848	780	670	1477
D4-270/DPH	1129	848	780	660	1455
D4-300/DPI	1129	848	780	670	1477
D4-300/DPH	1129	848	780	660	1455
D4-320/DPI	1129	848	780	670	1477

* Dry weight including drive and propeller.

D6 AQUAMATIC



6-cylinder, 4-stroke, direct-injected, and aftercooled marine diesel engine.

Bore x Stroke (mm): 103 x 110

Displacement (l): 5.5

PROPULSION

Engine	Drive	Crankshaft power kW/hp	Prop. shaft power kW/hp	Rated rpm	Number of Cyl.	Displ. liters / in ³	Rating	Cooling system
D6-300A	DPI	221 / 300	212 / 288	3300	6	5.5 / 335.6	4	HE
D6-300A	DPH	221 / 300	212 / 288	3300	6	5.5 / 335.6	4	HE
D6-340A	DPI	250 / 340	240 / 326	3400	6	5.5 / 335.6	4	HE
D6-340A	DPH	250 / 340	240 / 326	3400	6	5.5 / 335.6	4	HE
D6-380A	DPI	280 / 380	269 / 366	3500	6	5.5 / 335.6	4	HE
D6-380A	DPH	280 / 380	269 / 366	3500	6	5.5 / 335.6	4	HE
D6-400A	DPI	294 / 400	282 / 384	3500	6	5.5 / 335.6	5	HE
D6-400A	DPH	294 / 400	282 / 384	3500	6	5.5 / 335.6	5	HE
D6-440A	DPI	324 / 440	311 / 422	3700	6	5.5 / 335.6	5	HE

HE = Heat Exchanger

DIMENSIONS AND WEIGHTS*

Engine	L (mm)	W (mm)	H (mm)	kg	lb
D6-300/DPI	1365	851	780	755	1664
D6-300/DPH	1365	851	780	745	1642
D6-340/DPI	1365	851	780	755	1664
D6-340/DPH	1365	851	780	745	1642
D6-380/DPI	1365	851	780	770	1698
D6-380/DPH	1365	851	780	760	1676
D6-400/DPI	1365	851	795	790	1742
D6-400/DPH	1365	851	795	780	1720
D6-440/DPI	1365	851	795	790	1742

* Dry weight including drive and propeller.

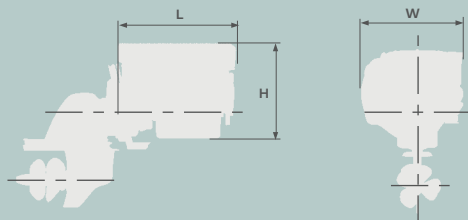

Not for installation.

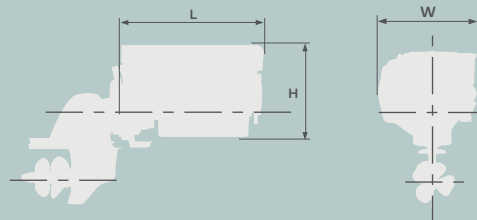

Not for installation.



VOLVO PENTA IPS



A revolutionary marine propulsion system. Volvo Penta IPS – Inboard Performance System – offers dramatically increased efficiency compared with inboard shafts. The patented, counter-rotating propellers work in undisturbed water and produce a completely horizontal thrust which results in 15% faster acceleration and 20% higher top speed. And thanks to the significantly reduced fuel consumption, cruising range is also greatly improved (30%).

Joystick manoeuvring

The optional joystick makes docking and slow-speed manoeuvring easier than ever before. The secret behind the amazing moves is the Volvo Penta IPS system with its individually steerable drive units.

Easy manoeuvring, powerful handling

Steerable propulsion units, instead of fixed propellers and rudders, means that Volvo Penta IPS turns and points the entire thrust in the desired direction. The result is 50% better turning radius and car-like manoeuvring for easy docking, as well as predictable handling at higher speeds.

Complete and integrated system

The Volvo Penta IPS has been developed and is manufactured as a complete system with everything included – engine, propulsion unit including gear box, propellers, exhaust and seawater system, steering, and controls. The system is always used in at least twin-engine installation configurations.

VOLVO PENTA IPS



4-cylinder, 4-stroke, direct-injected, and aftercooled marine diesel engine.

Bore x Stroke (mm): 103 x 110

Displacement (l): 3.7

PROPULSION SYSTEM

Engine	Prop. shaft power kW/hp	Crankshaft power kW/hp	Rated rpm	Number of Cyl.	Displ. l/in ³	Rating	Cooling system
D6-IPS400	212 / 288	221 / 300	3300	6	5.5 / 336	4	HE
D6-IPS450	240 / 326	250 / 340	3400	6	5.5 / 336	4	HE
D6-IPS500	265 / 365	280 / 380	3500	6	5.5 / 336	4	HE
D8-IPS600	315 / 437	331 / 450	2700	6	7.7 / 469.7	3	HE
D8-IPS600 IMO III	315 / 437	331 / 450	2700	6	7.7 / 469.7	3	HE
D8-IPS650	355 / 495	374 / 509	2850	6	7.7 / 469.7	4	HE
D8-IPS650 IMO III	355 / 495	374 / 509	2850	6	7.7 / 469.7	4	HE
D8-IPS700	384 / 533	405 / 550	2900	6	7.7 / 469.7	4	HE
D8-IPS700 IMO III	384 / 533	405 / 550	2900	6	7.7 / 469.7	4	HE
D11-IPS650	354 / 482	374 / 510	2250	6	10.8 / 661	3	HE
D11-IPS800	434 / 590	459 / 625	2400	6	10.8 / 661	4	HE
D13-IPS900	485 / 659	515 / 700	2250	6	12.8 / 780	3	HE
D13-IPS1050	554 / 753	588 / 800	2300	6	12.8 / 780	4 & 5	HE
D13-IPS1200	624 / 848	662 / 900	2300	6	12.8 / 780	5	HE
D13-IPS1350	693 / 942	735 / 1000	2400	6	12.8 / 780	5	HE
D13-IPS900 IMOIII	485 / 659	515 / 700	2250	6	12.8 / 780	3	HE
D13-IPS1050 IMOIII	554 / 753	588 / 800	2300	6	12.8 / 780	4	HE
D13-IPS1200 IMOIII	624 / 848	662 / 900	2300	6	12.8 / 780	5	HE
D13-IPS1350 IMOIII	693 / 942	735 / 1000	2400	6	12.8 / 780	5	HE

DIMENSIONS AND WEIGHTS*

Engine	L (mm)	W (mm)	H (mm)	kg*	lb*
D6-IPS400	2211	848	780	885	1951
D6-IPS450	2211	848	780	885	1951
D6-IPS500	2211	848	780	900	1984
D8-IPS 600	2722	986	929	1420	3131
D8-IPS 650	2722	986	929	1420	3131
D8-IPS 700	2722	986	929	1420	3131
D11-IPS 650	3102	1006	989	1955	4310
D11-IPS 800	3102	1006	989	1955	4310
D13-IPS 900	3103	1124	1220	2470	5446
D13-IPS 1050	3103	1124	1220	2470	5446
D13-IPS 1200	3103	1124	1220	2475	5457
D13-IPS 1350	3103	1124	1220	2480	5467

* Dry weight including drive and propeller.

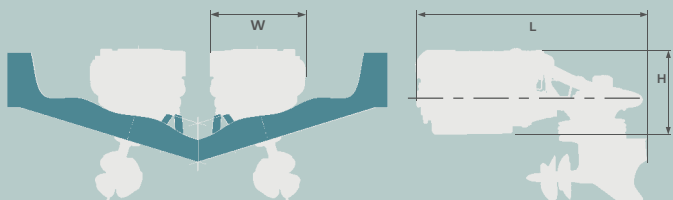

Not for installation.



MARINE GENSETS



All Volvo Penta gensets are delivered complete and tested, ready for installation on board. All equipment and sets are type approved by the major classification societies and can be delivered with certification.

Compact yet easy to service

Volvo Penta is known for compact engines and gensets that enhance service accessibility in engine rooms. Designed for quick, efficient maintenance, our engines are compatible with computerized diagnostic tools to simplify troubleshooting. We also offer a range of constant and variable speed gensets, factory-made to meet various power requirements with high efficiency and reliability, ensuring optimal performance in all conditions.

Fully compatible monitoring systems

Based on the Modbus protocol and equipped with a large number of hardwire contacts, the Volvo Penta control and monitoring system enables fast and safe integration with most switchboards and power management systems available on the market. The monitoring system and its range of functions – e.g. auto-start, shut-down and alarms – comply with all international standards.

Meeting future emission standards

Our engine range meets the current exhaust emission requirements and many of our engines already comply with the emission standards which come into effect over the next couple of years.

D8 MARINE GENSET



6-cylinder, 4 stroke, direct-injected, common rail, turbo-charged, and aftercooled marine diesel engine.

Bore x Stroke (mm): 110 x 135

Displacement (l): 7,7

MARINE GENSET HE, 1500RPM, 50HZ, CLASS F (105K AT 40°C)

Voltages- kWe						Emission certificate**	Emissions curve	Cooling system
Series Star	380	400	415	440	690			
Parallel Star	190	200	208	220	345			
Series Delta	220	230	240	254	400			
D8 MG / UCM274G	119	119	119	—	116	1, 4, 6	D2/E2	HE, KC
D8 MG / UCM274H	136	136	136	—	136	1, 4, 6	D2/E2	HE, KC
D8 MG / S4L1MC41	168	168	168	168	160	1, 4, 6	D2/E2	HE, KC
D8 MG / S4L1MD41	184	184	184	184	180	1, 4, 6	D2/E2	HE, KC
D8 MG / S4L1ME41	216	220	220	220	208	1, 4, 6	D2/E2	HE, KC
D8 MG / S4L1MF41	223	223	223	223	223	1, 4, 6	D2/E2	HE, KC

HE = Heat Exchanger, KC= Keel

MARINE GENSET HE, 1800RPM, 60HZ, CLASS F (105K AT 40°C)

Voltages- kWe						Emission certificate**	Emissions curve	Cooling system
Series Star	416	440	460	480	600	690		
Parallel Star	208	220	230	240	300	345		
Series Delta	240	254	266	277	346	400		
D8 MG / UCM274G	137	149	151	151	145	—	1, 4, 6	D2/E2
D8 MG / UCM274H	160	170	175	175	162	—	1, 4, 6	D2/E2
D8 MG / S4L1MC41	192	196	200	204	204	212	1, 4, 6	D2/E2
D8 MG / S4L1MD41	204	216	224	236	236	228	1, 4, 6	D2/E2
D8 MG / S4L1ME41	252	257	257	257	257	256	1, 4, 6	D2/E2
D8 MG / S4L1MF41	257	257	257	257	257	257	1, 4, 6	D2/E2

HE = Heat Exchanger, KC= Keel

DIMENSIONS AND WEIGHTS*

Engine	L (mm)	W (mm)	H (mm)	kg	lb
D8 MG/UCM274H	2259	1051.50	1650	1496	3298
D8 MG/S4L1MC41	2513	1051.50	1650	1710	3780
D8 MG/S4L1MD41	2513	1051.50	1650	1810	3990
D8 MG/S4L1ME41	2513	1051.50	1650	1894	4176
D8 MG/S4L1MF41	2603	1051.50	1650	2030	4475

* Dimensions and weights based on heat-exchanger cooled, single-bearing gensets.

** Emission Certificate:

- 1 – IMO tier II
- 4 – China II
- 6 – IMO tier III

D13 MARINE GENSET



6-cylinder, 4-stroke, direct-injected, turbo-charged, and aftercooled marine diesel engine.

Bore x Stroke (mm): 131 x 158

Displacement (l): 12.78

MARINE GENSET HE, 1500RPM, 50HZ, CLASS F (105K AT 40°C)

Voltages- kWe						Emission certificate**	Emissions curve	Cooling system
Series Star	380	400	415	440	690			
Parallel Star	190	200	208	220	345			
Series Delta	220	230	240	254	400			
D13 MG / S4L1MF41	248	248	248	248	240	2, 6, 7	D2/E2	HE, KC, RC
D13 MG / S5L1MC41	284	284	284	284	272	2, 6, 7	D2/E2	HE, KC, RC
D13 MG / S5L1MD41	324	332	332	332	324	2, 6	D2/E2	HE, KC, RC
D13 MG (FE) / S4L1MF41	248	248	248	248	240	6	D2/E2	HE, KC, RC
D13 MG (FE) / S5L1MC41	284	284	284	284	272	6	D2/E2	HE, KC, RC
D13 MG (FE) / S5L1MD41	324	332	332	332	324	6	D2/E2	HE, KC, RC

HE = Heat Exchanger, KC= Keel, RC = Radiator

MARINE GENSET HE, 1800RPM, 60HZ, CLASS F (105K AT 40°C)

Voltages- kWe						Emission certificate**	Emissions curve	Cooling system
Series Star	416	440	460	480	600	690		
Parallel Star	208	220	230	240	300	345		
Series Delta	240	254	266	277	346	400		
D13 MG / S4L1MF41	292	300	300	300	300	300	2, 6, 7	D2/E2
D13 MG / S5L1MC41	341	341	341	341	341	341	2, 6, 7	D2/E2
D13 MG / S5L1MD41	370	380	380	380	380	380	2, 6	D2/E2
D13 MG (FE) / S4L1MF41	292	300	300	300	300	300	1	D2/E2
D13 MG (FE) / S5L1MC41	341	341	341	341	341	341	1	D2/E2
D13 MG (FE) / S5L1MD41	370	380	380	380	380	380	1	D2/E2

HE = Heat Exchanger, KC= Keel

DIMENSIONS AND WEIGHTS*

Engine	L (mm)	W (mm)	H (mm)	kg	lb
D13 MG/ S4L1MF41	3147	1086	1814	3070	6768
D13 MG/ S5L1MC41	3219	1086	1813	3175	6999
D13 MG/ S5L1MD41	2817	1174	1799	3305	7286

* Dimensions and weights based on heat-exchanger cooled, single-bearing gensets.

** Emission Certificate:

- 1 – IMO tier II
- 2 – EPA Tier 3
- 6 – IMO tier III
- 7 – Stage V

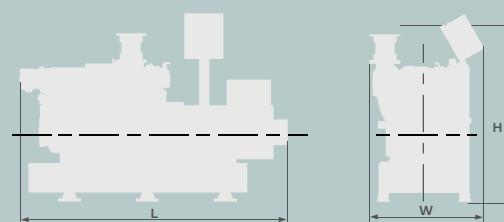
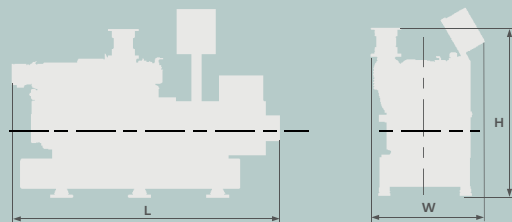

D16 MARINE GENSET



6-cylinder, 4-stroke, direct-injected, turbo-charged, and aftercooled marine diesel engine.

Bore x Stroke (mm): 144 x 165

Displacement (l): 16.1

MARINE GENSET HE, 1500RPM, 50HZ, CLASS F (105K AT 40°C)

Voltages- kWe						Emission certificate**	Emissions curve	Cooling system
Series Star	380	400	415	440	690			
Parallel Star	190	200	208	220	345			
Series Delta	220	230	240	254	400			
D16 MG / S5L1ME41	380	392	404	404	352	1, 2, 4, 6	D2/E2	HE, KC, RC
D16 MG / S5L1MF41	404	420	427	427	404	1, 2, 4, 6	D2/E2	HE, KC, RC
D16 MG / S6L1MC41	504	505	505	505	504	1, 2, 4, 6	D2/E2	HE, KC, RC
D16 MG / LSAM 47.3 L10	472	472	472	—	400	1, 2, 4, 6	D2/E2	HE, KC, RC
D16 MG / LSAM 49.3 S4	—	—	—	—	440	1, 2, 4, 6	D2/E2	HE, KC, RC
D16 MG / LSAM 49.3 M6	504	504	504	—	480	1, 2, 4, 6	D2/E2	HE, KC, RC

HE = Heat Exchanger, KC= Keel, RC = Radiator

MARINE GENSET HE, 1800RPM, 60HZ, CLASS F (105K AT 40°C)

Voltages- kWe						Emission certificate**	Emissions curve	Cooling system
Series Star	416	440	460	480	600	690		
Parallel Star	208	220	230	240	300	345		
Series Delta	240	254	266	277	346	400		
D16 MG / S5L1ME41	450	470	475	475	472	475	1, 2, 6	D2/E2 HE, KC, RC
D16 MG / S5L1MF41	495	505	505	505	502	502	1, 2, 4, 6	D2/E2 HE, KC, RC
D16 MG / S6L1MC41	555	555	555	555	555	555	1, 4, 6	D2/E2 HE, KC, RC
D16 MG / LSAM 47.3 L10	—	505	505	505	—	436	1, 2, 4, 6	D2/E2 HE, KC, RC
D16 MG / LSAM 49.3 S4	—	—	—	—	500	1, 2, 4, 6	D2/E2	HE, KC, RC
D16 MG / LSAM 49.3 M6	—	504	504	504	—	503	1, 2, 4, 6	D2/E2 HE, KC, RC
D16 MG / LSAM 49.7 S4	—	—	—	—	—	525	6	D2/E2 HE, KC, RC

HE = Heat Exchanger, KC= Keel

DIMENSIONS AND WEIGHTS*

Engine	L (mm)	W (mm)	H (mm)	kg	lb
D16 MG/S5L1ME41	3122	1177	1842	3776	8325
D16 MG/S5L1MF41	3122	1177	1842	4034	8894
D16 MG/S6L1MC41	3265	1177	1842	4271	9396

* Dimensions and weights based on heat-exchanger cooled, single-bearing gensets.

** Emission Certificate:

- 1 – IMO tier II
- 2 – EPA Tier 3
- 4 – China II
- 6 – IMO tier III

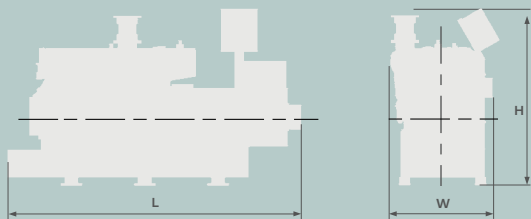

Not for installation.

MARINE VARIABLE SPEED GENSET



VARIABLE SPEED MARINE GENSET HE, 1500RPM, 50HZ, CLASS F (105K AT 40°C)

Engine	Crankshaft power (kWm)	Electrical power (kWe)	Displacement (Liter)	Inches	Emission certificate**	Emissions curve	Cooling system
D8-MH (VG)	221	193 @ 1800rpm	7.7	469.7	1	C1	HE, KC
D8-MH (VG)	296	240 @ 2100rpm	7.7	469.7	1	C1	HE, KC
D8-MH (VG)	221	193 @ 1800rpm	7.7	469.7	6	C1	HE, KC
D8-MH (VG)	296	240 @ 2100rpm	7.7	469.7	6	C1	HE, KC
D13-MH (VG)FE	294	257 @ 1800rpm	12.8	780	1	C1	HE, KC, RC
D13-MH (VG)FE	368	277 @ 1800rpm	12.8	780	1	C1	HE, KC, RC
D13-MH (VG)FE	441	385 @ 1900rpm	12.8	780	1	C1	HE, KC, RC
D13-MH (VG)	294	257 @ 1800rpm	12.8	780	6	C1	HE, KC, RC
D13-MH (VG)	368	277 @ 1800rpm	12.8	780	6	C1	HE, KC, RC
D13-MH (VG)	441	385 @ 1900rpm	12.8	780	6	C1	HE, KC, RC

HE = Heat Exchanger, KC= Keel, RC = Radiator

DIMENSIONS AND WEIGHTS

Sizes and weight - see the respective engine on the previous pages.

** Emission Certificate:

- 1 – IMO tier II
- 6 – IMO tier III



VOLVO PENTA ACCESSORIES

The buttons on the joystick put a unique combination of functions within your easy reach. Dynamic Positioning, Joystick Driving, Joystick Docking and High Mode offer easier handling, increased safety, and reliable operation.



JOYSTICK DRIVING

A whole new way to maneuver with precision at all speeds. You steer comfortably with the joystick. The integrated autopilot supports by automatically engaging after every course change.



JOYSTICK DOCKING

Makes docking easy, even in tough conditions. Forget complicated manoeuvres in close quarters – just move the joystick in any direction and your boat will follow. You can install up to six Joystick Docking stations on your boat.



VOLVO PENTA ASSISTED DOCKING SYSTEM

The next generation of marine automation. It simplifies vessel docking by removing the dynamics of wind and current, and improves your control for maneuvering in tight spaces, to make docking vessels safe and easy in challenging conditions



DYNAMIC POSITIONING SYSTEM

Press the button and your boat's position and heading are held within a very limited area – the EVC system transforms GPS data into steering angles, gear shifts and throttle positions.

HIGH MODE When you need extra power from the system, just press the High Mode button.

Feature	Volvo Penta IPS	Aquamatic Sterndrive	Forward Drive	Inboard shaft
Trip computer	○	○	○	○
Cruise control	○	○	○	○
Powertrim Assistant	—	○	○	—
Single-lever mode 1)	○	○	—	○
Low-speed mode	○	● 4)	—	○ 5)
Autopilot 3)	○	○	—	○
Tow mode for water sport 2)	—	○	○	—
Sportfish mode	△	—	—	—
Joystick Docking 1, 3)	△	△	—	△
Dynamic Positioning System 1, 3)	△	△ 4)	—	—
Joystick Driving 3)	△	△	—	△
Battery Management System	△	△	△	△
Electronic Steering	●	□ / ● 4)	—	□
Interceptor System 1)	□	□	□	□
Glass Cockpit system 10"-24"	□	□	□	□

● Standard

○ Factory installation recommended. Retrofit by dealer possible.

△ Factory installation highly recommended. Retrofit by dealer possible, but can involve major installation work.

□ Only factory installation. No retrofit.

— Not available

- 1) Twin, triple or quadruple installation
- 2) Single installation with side-mounted control
- 3) Requires electronic steering
- 4) DPI drives
- 5) D4-D13



Some features specified as options in the table may be included as standard in some markets.



KEEPING UPTIME HIGH – AND TOTAL COST OF OWNERSHIP LOW

MAXIMUM UPTIME always starts with premium product quality. Well-designed, robust, high-performing engines and drive systems. The materials, the excellence in engineering and the innovativeness. Proven technologies means reliability. Volvo Penta marine commercial equipment is tried and tested in demanding conditions all over the world – for more than a hundred years.

PREDICTABILITY increases uptime. Volvo Penta service agreements can be tailored to your operating needs and budget to include anything from regular inspections to a comprehensive service and maintenance program that includes preventive repairs. The service agreement is between you and your Volvo Penta dealer, and helps you maximize uptime, lower total cost of ownership and improve cost control.

Unique fuel efficiency

Fuel efficiency is the most decisive factor for cost of operation and cost of ownership. Fuel consumption accounts for the largest portion of your total operational cost. Any fuel saving you can achieve goes straight to the bottom line.

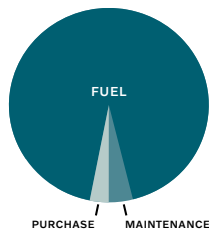

“Wherever, whenever
– we are there to support.”

On call 24/7/365 in 28 languages

Our global dealer network – your first line of contact – is backed up by Volvo Penta Action Service, a phone-based breakdown and support service providing assistance 24 hours a day, every day of the year.

Global dealer network, with local expertise

The Volvo Penta marine commercial dealer network covers 156 countries, with 2.068 authorized dealers worldwide. They comply with our marine commercial dealer operating standard, which is designed to ensure consistently high-quality service and support. This includes 24/7 accessibility, parts availability, advanced diagnostics, and technical competence to secure the local expertise necessary to keep your business going.

Find your nearest Volvo Penta dealer on volvopenta.com or download our dealer locator app.

World class parts distribution network

As part of the Volvo Group, we benefit from one of the world's most efficient parts distribution networks in the industry – the Volvo Group Logistics Services. Working from 17 key locations around the world, 24/7, to ensure you get the right parts at the right place at the right time.



A GENUINE PROMISE

Volvo Penta global service and support - ensuring business is running at full capacity.

VOLVO PENTA GLOBAL SERVICE AND SUPPORT

- Global marine commercial dealer network
- World class parts distribution network
- Volvo Penta Action Service
- Exchange Components
- Repair & Overhaul kits
- Service Agreements
- Volvo Penta Oil Analysis
- Quickline repowering service

“Ensuring your business
is running at full capacity.”